

®

ES

HSA3000

100% wirefree
security
alarm system

Installation

Programming

Operating

Keep in a handy place for reference and for
future maintenance

Intelligent Security & Fire Ltd



Helpline 01902 635998

Introduction

General system overview

Thank you for choosing the Yale HSA3000 Security Alarm System. This simple to install system has been designed with the user in mind.

The siren has a sounder and strobe LEDs to attract attention. In addition, two window stickers are included in the pack. Please stick them in a front and rear window.

No connections

All the components are self contained and no connections are needed between the units. There is no need to damage the home decor, lift carpets or run cables.

Number of devices

You can install up to 20 devices in the system. This includes accessories such as smoke detectors, keypad remote controls and help watches.

Long battery life

All the components are battery operated with batteries included and so avoids wiring into the 230V mains supply and requiring the services of a qualified electrician.

Alkaline batteries must be used as replacements. Regular testing and battery changes (when notified by the system) will ensure reliability and peace of mind.

Tamper proof system

The security detectors and external siren are 'tamper' protected. Any unauthorised interference with these items will result in an alarm. This feature can be turned off by the user when a battery change is required.

Take care of your safety

Display extreme caution when using ladders or steps, please follow manufacturer instructions.

Be careful when using hand and power tools and follow the manufacturers' guidelines when using them. Take care that the correct tools are used. Wear goggles or protective clothing where required.

The external Siren is extremely loud, please ensure you replace the cover and retreat to a safe distance before testing.

Warranty

Please complete and return the warranty card. You will then be sent your certificate and number.

Yale offer extended periods of warranty, please see warranty card for details.

Calling for help

Yale have a helpline team who are there to offer advice or solve problems over the phone.

Have your certificate number ready.

Helpline 01902 635998

Intelligent Security & Fire Ltd

Recommended installation sequence

We recommend you follow the easy start sequence, headings numbered 1-5.
Subsequent sections provide:

- Use of additional accessories including keypad remote control, smoke detector and help watch

Carton contents

External siren
Keyfob remote controller
Passive infrared (PIR) detector
Door/Window contact
Door/Window contact magnet

2 x 1.5V AAA alkaline cells
3 x 1.5V AA alkaline cells
1 x 12V battery 23A/MN21
4 x 1.5V D alkaline cells

Large adhesive pad
Small adhesive pad
2 x small wall plugs
6 x medium wall plugs
4 x large wall plugs
4 x 4mm x 30mm cross head fixing screws
6 x 3.5mm x 16mm cross head fixing screws
2 x 3mm x 12mm cross head fixing screws
2 x window stickers

Contents

1	Insert the batteries	4-5
2	Program the siren	6-7
3	Location planning	8-9
4	Mounting and testing	10
5	Using for the first time	12
	Installing and using accessories	13
	Changing the batteries	15
	Specifications	17
	Trouble shooting	18
	Notes	19
	Key points	Back cover

Intelligent Security & Fire Ltd

1 Insert the batteries

The easiest way to get to know the system and get it up and running quickly is to get all the devices and accessories programmed on a table top before locating and mounting them.



Siren

WARNING

The siren is very loud, be prepared for a loud noise. Take care not to activate the siren unnecessarily.

- 1 Remove the cover by unscrewing the single screw located at the bottom.
- 2 Remove the covers of the two internal compartments.
- 3 Insert the four D batteries as shown. There is a slight pause while the unit initialises. The siren will then beep and the LEDs flash.

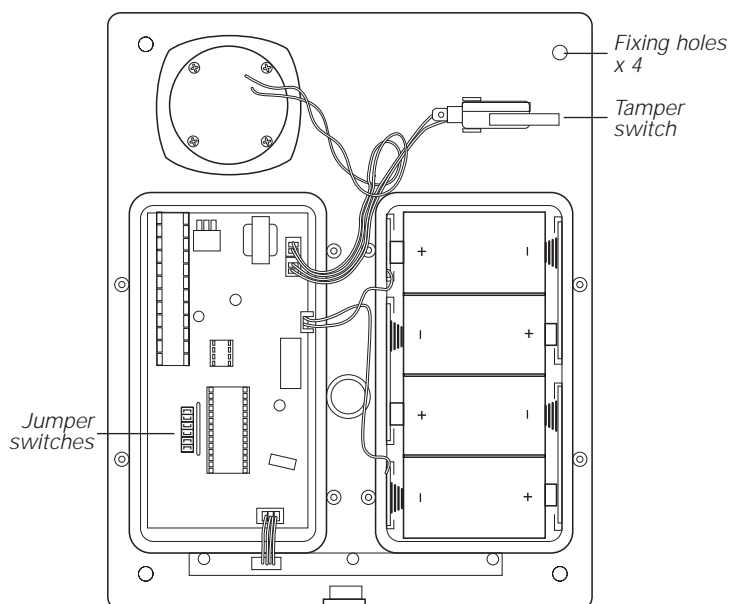

PIR movement detector

Remove the fixing screw and cover assembly and insert the three AA batteries as shown.

- The light steadily flashes for 30 seconds while components initialise.

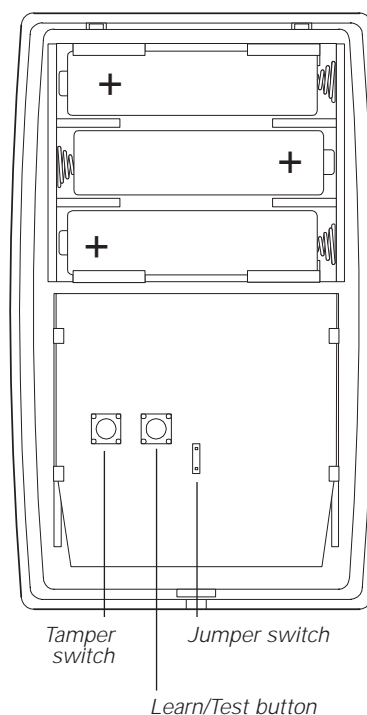

Keyfob remote controller

Slide off the battery cover, insert the battery as shown, and replace battery cover. Switch on.

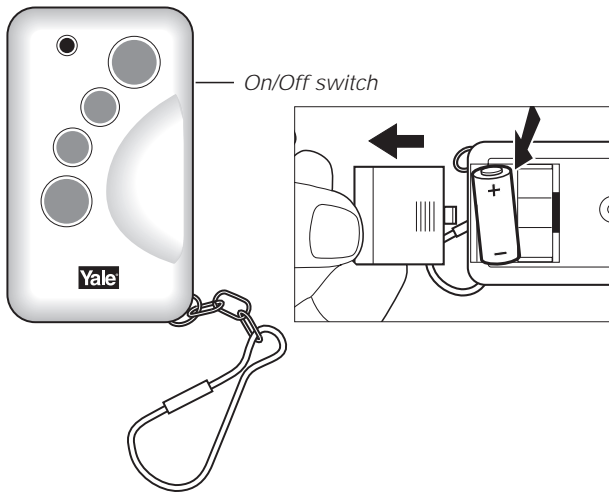

Door/window contact

- 1 Remove the cover by loosening the fixing screw.
- 2 Insert the two AAA batteries as shown. The indicator will flash briefly.

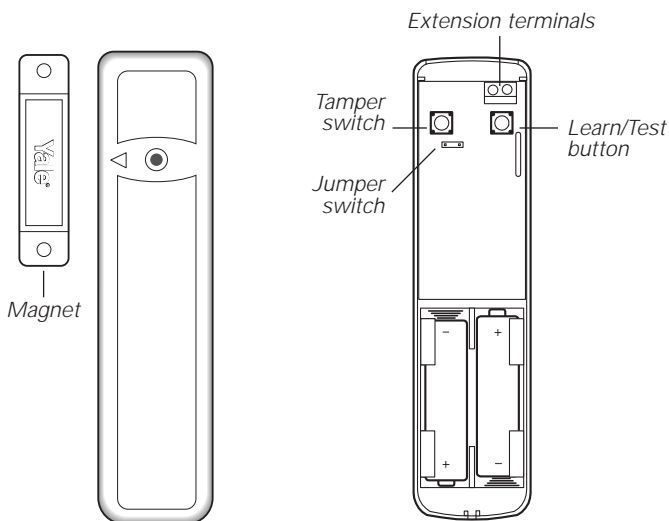

Keypad remote control accessory

Remove the cover and insert the PP3 battery as shown. The light will flash briefly while components initialise.

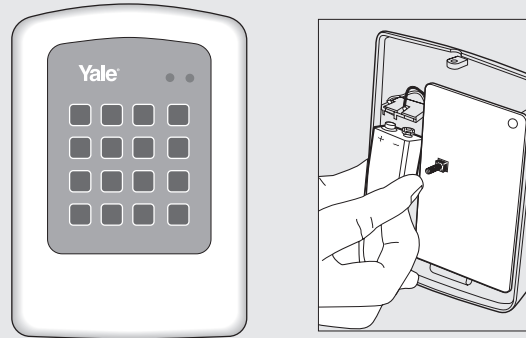

Smoke detector accessory

Remove the bayonet cover and insert the PP3 battery as shown.

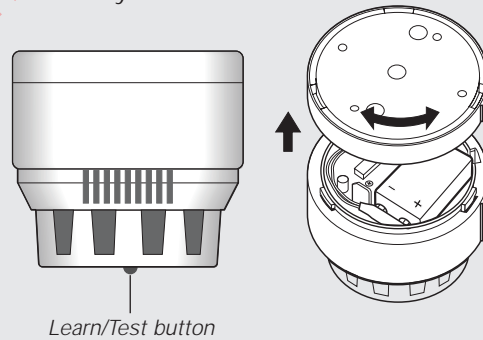

Help watch accessory

This has the permanent battery already inserted. The watch cannot be opened.



2 Program the siren

The siren contains the systems control unit. First, teach the siren to recognise (learn) all the devices.

Use of jumper switches

The siren, PIR and door contact have internal switches, or jumpers, which control various functions. The jumpers are either on or off. On is when the jumper connects two pins, off when it is removed. To prevent the jumper from being lost when removed, it can be 'parked' on one pin as shown:

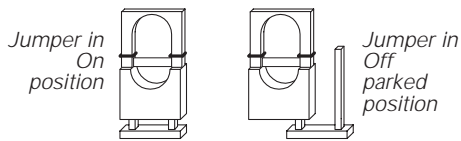

Programming the siren

WARNING
The siren is very loud, be prepared for a loud noise. Take care not to activate the siren unnecessarily.

The siren is programmed by the jumper switches in the left hand compartment.

Ensure all jumpers are in the On position before starting.

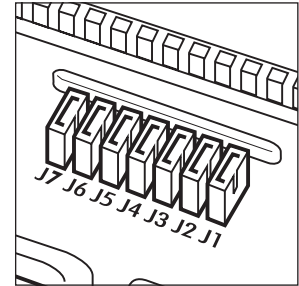

- 1 Lift off jumper number 1 and park it. The siren will beep and flash. The siren is now in learn mode.
- 2 Learn-in the keyfob by pressing the Arm button until the siren confirms.
- 3 Replace jumper 1 to the On position, the siren will confirm with a beep and a flash as it exits learn mode.
- 4 Disable the system tampers by pressing and holding the Home and Arm buttons simultaneously until the siren confirms with a beep (approx 5 seconds).
 - If accidentally left in the tamper disable mode, the system will revert to normal after about 1 hour.
- 5 Put the siren into learn mode again by pressing and holding the Panic and Home buttons simultaneously until the siren confirms with a beep and a flash (approx 5 seconds).
 - If accidentally left in the learn mode, the system will revert to normal after about 3 minutes.

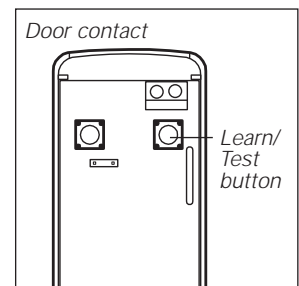
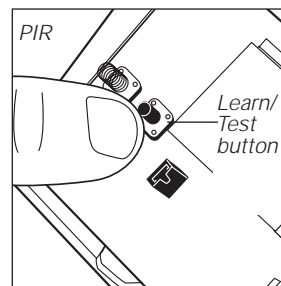

- 6 Press the Learn button inside the PIR, the siren will confirm.
- 7 Press the Learn button inside the door contact, the siren will confirm.
- 8 Exit learn mode by pressing Disarm.

Further siren programming

The siren can be further programmed by the use of jumpers if you desire.

J7	Jamming detection
J6	Clear memory (leave On)
J5	Standalone mode (leave On)
J4	Siren activation time
J3	Siren activation time
J2	Strobe activation mode
J1	Learning-in mode (leave On)

Jumper positions

J7 on = jamming detection off; off = jamming detection on
J6 on = normal, J6 off = clear memory
J5 on = stand alone operation; off = slave operation, not used in this system
J3 on, J4 on = 3 minute siren on period J3 off, J4 on = 5 minute siren on period J3 on, J4 off = 10 minute siren on period J3 off, J4 off = 1 second siren on test period
J2 on = LEDs on during siren period; off = LEDs on until system disarm
J1 on = normal; off = learn-in mode

- Jumper 5 must be left in the On position.
- J6 must be left on in normal service otherwise the the siren will lose its learn-in memory when the batteries are replaced.
- With J7 off, jamming by radio interference is detected when continuously present for more than 30 seconds and activates the siren only when armed.
- If jumper 3 and jumper 4 are removed during the learning-in process, the siren will sound for 1 second if accidentally activated and is useful for testing. Ensure they are replaced before replacing the covers.
- 9 Replace the battery and electronics compartment covers, ensuring the gasket between the electronics compartment and cover is correctly located and the wires placed in their slots to ensure a good seal from the environment.

Tamper alarm

If the siren detects a tamper condition it will activate the siren for the programmed period. If the tamper condition persists the siren will sound a series of five pips either every time the system is armed or when the tamper is enabled, to indicate a fault.

Previous alarm warning

If there has been an alarm when you were away the siren will sound and flash for 3 seconds when being disarmed.

Warning If the siren is activated for 3 seconds when you disarm your system there could be an intruder still in your premises.

Strobe led visibility

The strobe leds are intended to work together with the siren to identify the alarm source.

The strobe is not designed to be viewed from directly underneath or from the sides. It is designed to be clearly visible from 10 to 50 metres in normal daylight conditions, away from direct sunlight.

3 Location planning

Work out the best places to locate the devices for maximum protection.

Range

All devices must be within 30 metres of the control unit and must not be mounted on or near large metal objects.

Tamper switches

If mounting a device on an uneven surface, ensure that the tamper switch that protrudes from the rear is pressed in firmly.

Smoke detector accessory

- Mount on the ceiling at the top of a stairwell, or where smoke would most likely be detected
- Install additional detectors if there are closed doors preventing smoke from reaching detectors

Help watch accessory

For the elderly or infirm, and worn on the wrist. When pressed for the required period of time will activate the alarm.

PIR movement detector

- In a position such that an intruder would normally move across the PIR's field of view
- Between 1.7 and 2.3m above floor level
- In a corner to give the widest view
- Where its field of view will not be obstructed eg by curtains, ornaments etc
- Not pointing directly at sources of heat e.g. fires or boilers, and not above radiators
- Not pointing directly at a window facing the sun
- Not pointing at a door protected by a door contact

Intelligent Security & Fire Ltd

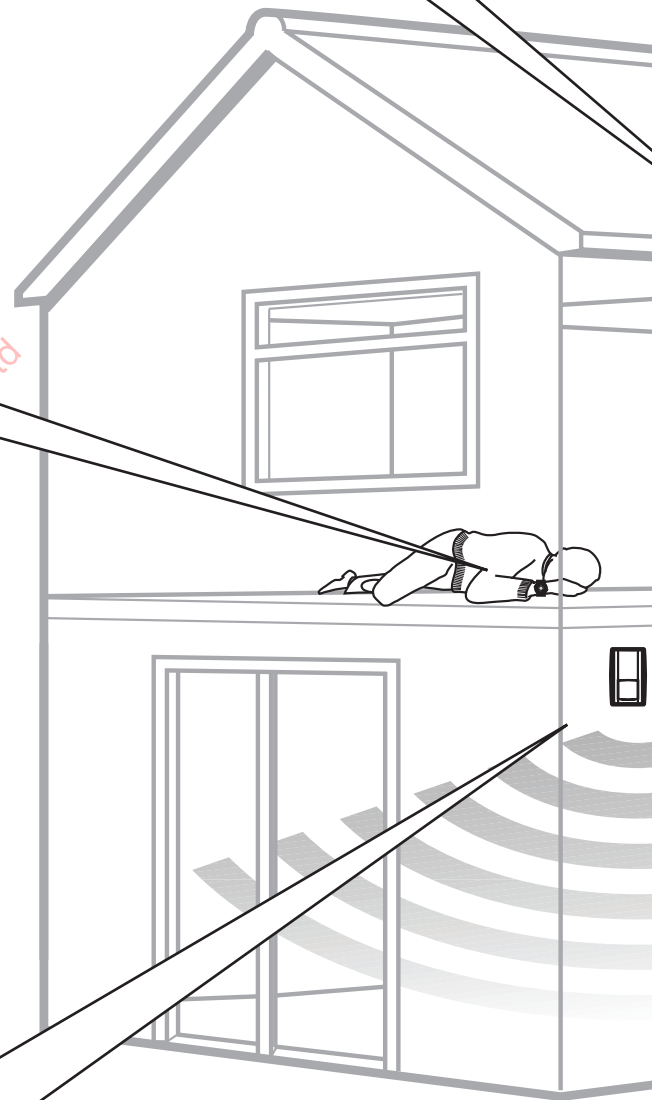

Siren

Warning

The siren is extremely loud, so cover the unit before testing.

- Choose a prominent position high up on an external wall, out of reach of the ground
- Away from large metal structures and obvious sources of electrical interference

Door/Window contact

Select a door that will be the main point of entry and exit, usually your front door.

- Mount as high as possible
- Do not aim a PIR at this door or window

Keyfob

Can be used inside or outside the property and can be kept on your keyring.

Keypad accessory

- Accessible when entering
- Not visible from outside
- Protected by another device
- Chest height for ease of use
- Not outdoors

Extend the system

Extend the system in the future to increase your security or as your needs change.

For example, add extra PIR detectors in the garage and bedrooms and extra door/window contacts.

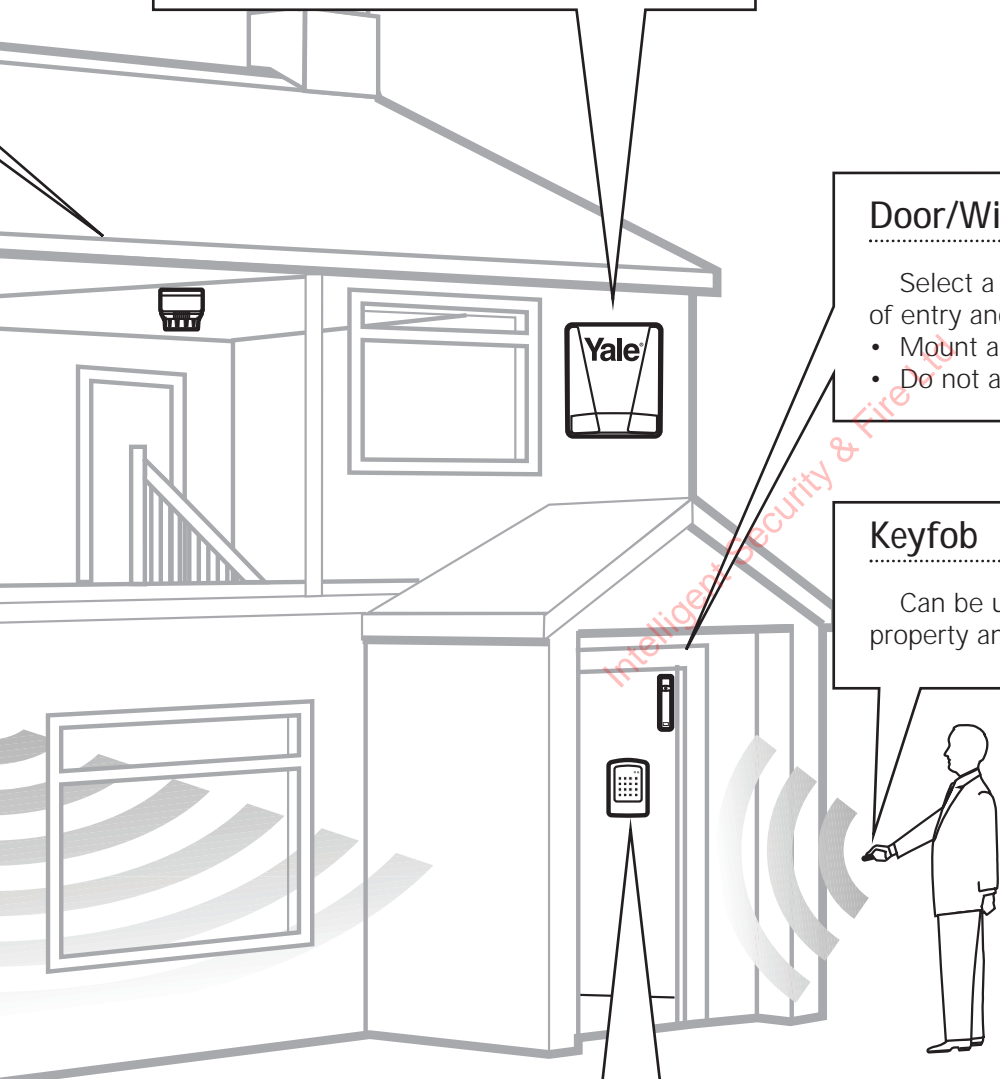

4 Mounting and testing

Before mounting detectors ensure that the system tamper is disabled as described in section 2, point 4.

Testing the radio performance

Before permanently installing the system, check that the siren will receive the system radio transmissions by doing a simple radio range test.

- 1 Ensure that the system tamper is disabled.
- 2 Mount the siren temporarily in the location you have chosen.
 - Use either a masonry nail or single screw in the siren base keyhole to temporarily fix in place.
- 3 Hold the device in the desired location and activate, check that the siren responds.
 - The PIR and door contact can be tested by pressing the learn/test button.
 - The keypad can be tested by arming and disarming the system.
 - The smoke detector is tested by pressing the button until the siren responds (approx 10 seconds).
- 4 When you are satisfied that the devices work in their chosen locations, proceed with the installation as described below.
 - If the device does not respond, the location may be out of radio range, try alternative locations until reliable radio contact is obtained.

Alternative mounting methods

Yale provide two methods of mounting. Choose either the self adhesive pads or the screws and wall plugs supplied.

Self adhesive installation *for door/window contact and smoke detector accessory*

Clean the surface with a suitable degreaser. Remove the protective covering from one side of the double sided adhesive pad and firmly apply to the back of the device. Next remove the other cover and firmly press the item onto the desired location.

- Do not use the adhesive pad method of installation on a surface with peeling or cracked paint, or on a rough surface.

Screw mounting

Remove the front of the device, and, if necessary, break through the appropriate knockout (where the plastic is thinner).

Using the holes as a template, drill holes in the surface and insert the wall plugs if fixing into plaster or brick.

PIR movement detector

The PIR has a built-in sleep timer to save battery power. If there is no movement in front of the PIR for 1 minute, the PIR will become 'ready to signal' and movement will now be reported. The PIR will sleep for 1 minute after. Any movement detected in sleep time will not be reported and will extend the sleep period by 1 minute. This feature is designed to conserve battery life.

Ensure the test/normal mode jumper switch is in the test 'On' position. This reduces the sleep time to a few seconds and enables the LED to flash every time movement is detected.

- 1 Screw the rear case to the wall using two of the knockouts shown, as described above under Alternative mounting methods. The case has angled back edges for neat corner mounting. Screw the PIR front on.

- 2 Walk around the protected area noting when the LED flashes and check that the detection coverage is adequate.

- Remember to wait a few seconds after the PIR has detected movement.
- Do not try to test the detection pattern by walking straight up to, or away from the detector.
- 3 When you are satisfied with the detection coverage, remove the PIR, place the jumper in the normal 'Off' parked position and screw the PIR back on to its case.
 - With the jumper in the normal position the LED will not normally light unless there is a problem, either a low battery or a tamper condition. In the event of a low battery, replace the exhausted batteries with fresh alkaline replacements.
 - Do not position a PIR to look directly at a door protected by a door contact, this could cause the door contact and PIR radio signals to be transmitted at the same instant when entering, cancelling each other out.
 - Ensure the jumper is in the normal Off position when testing is finished, otherwise low battery and tamper conditions will not be shown.

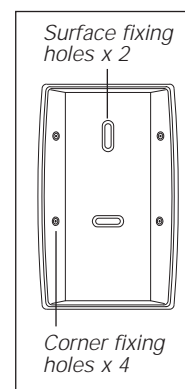

Door/Window contact

- 1 Ensure the jumper switch is in the test 'On' position.
 - In this position the indicator light will illuminate every time the door contact is operated.
- 2 Fit as described above under Alternative mounting methods, mounting the detector base on the frame and aligning the magnet by the arrow as shown.
 - The magnet should not be more than 8mm from the detector when the door is closed.
 - Ensure the tamper switch spring is positioned so that it makes contact with the mounting surface through the tamper switch aperture.
 - If the door contact cannot be mounted on the doorframe, use the HSA3090 multiple door/window contact accessory kit with a length of wire to mount the door contact remotely.
 - When fitting to a window, fix the magnet to the moving part and the detector to the frame.
- 3 Fix the detector on its base and secure with screw. Test it by opening and closing the door or window. The light will flash when an open condition is detected.
- 4 Remove the detector, put the jumper switch in the normal 'Off' position. Screw the detector back onto its base.
 - When the jumper is in the normal Off position the indicator light will normally be off. It will only light if there is a problem, either a low battery or a tamper condition.
 - Ensure the jumper is in the normal Off position when testing is finished, otherwise low battery and tamper conditions will not be shown.

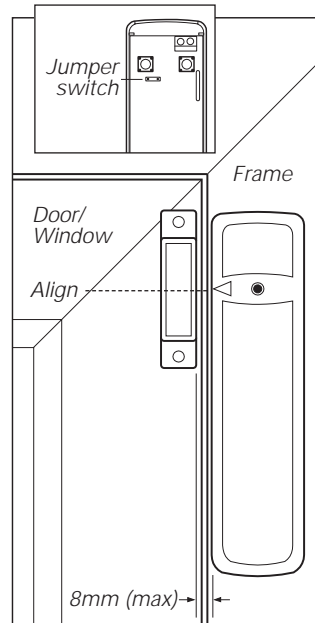

Adding door/window contacts

More than one window and door can be protected by a door contact using the HSA3090 multiple door/window contact accessory kit. The contacts must be wired to the auxiliary switch terminal block as shown.

Siren

WARNING

The siren is extremely loud!

The tamper switch plunger protrudes through the back of the unit, so that if the siren is pulled from the wall the alarm is activated. Ensure it is fully depressed when the siren is mounted. If there is a gap, pack with a suitable spacing material.

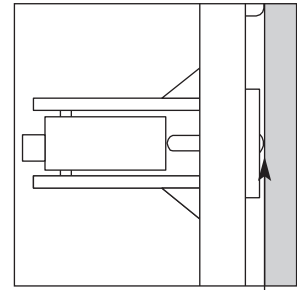

Tamper switch plunger must be pressed in fully by wall surface

- 1 Find suitable location, as previously described in section 3.
- 2 Disable the system tamper by pressing and holding the Home and Arm buttons simultaneously until the siren confirms with a beep (approx 5 seconds).
- 3 Using the large screws provided, mount on wall through the base plate mounting holes shown.
- 4 Fix the siren cover with the securing screw.
- 5 Put system into normal tamper detection mode by pressing and holding the keyfob Arm and Panic buttons simultaneously until the siren confirms with a beep (approx 5 seconds).
- 6 Test by arming and disarming with the keyfob. If 5 pips sound the tamper is not correctly set.

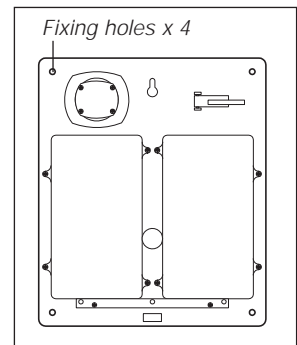

Installation is complete.

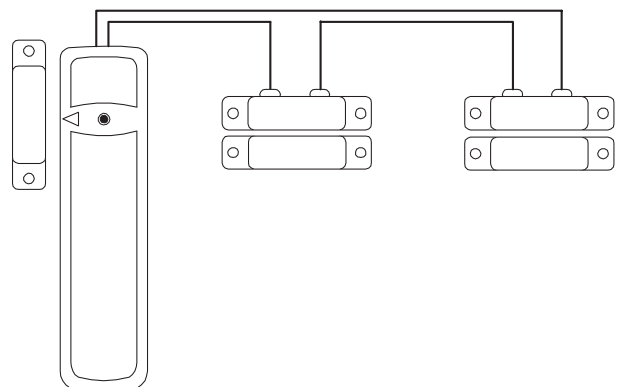

5 Using for the first time

Arm and disarm the system and practice using it. Trigger the alarm by arming the system and opening protected doors/windows and walking past PIR's. Now's the time to show the rest of the family how simple it is to use.

Arming

Press Arm on the keyfob for at least 1 second. The delay is designed to prevent accidental operation. The siren will respond by beeping once and the LEDs flashing.

Disarm

Press Disarm on the keyfob for at least 1 second. The siren will respond by beeping twice and the LEDs flashing from side to side.

Panic

Press the Panic button for 3 seconds, the keyfob LED will flash and the siren will sound and flash.

Stopping the alarm

If the siren is sounding and the strobe flashing:
Press Disarm on the keyfob.

- The on/off switch at the side prevents the keyfob from transmitting accidentally.
- The Home button is not operational in this system.

Intelligent Security & Fire Ltd

Installing and using accessories

To provide additional protection you can add additional keyfobs, PIR's, door and window contacts, a keypad, a help watch and a smoke detector.

Putting the system in and out of learn mode

Put the system into learn mode and disable the system tamper by using the keyfob as follows.

- 1 Disable tamper by pressing Arm and Home buttons simultaneously until the siren confirms (approx 5 seconds).
 - 2 Enter learn mode by pressing the Panic and Home buttons simultaneously until the siren confirms by beeping (approx 5 seconds).
 - 3 Learn-in the appropriate device as described below.
 - 4 Exit learn mode by pressing Disarm, siren will confirm.
 - 5 Enable tamper by pressing Arm and Panic buttons simultaneously until the siren confirms (approx 5 seconds).
- If accidentally left in learn mode, the system will revert to normal in about 3 minutes.
 - If accidentally left with tamper disabled, the system will revert to normal in about 1 hour.

Adding keypad accessory

- 1 Follow sections 1, 3 and 4 (Inserting batteries, Location planning and Mounting).
- 2 Enter the default 0000 PIN code and press TEST, the keypad Tx led will flash showing that it is in program mode.
- 3 With the system in learn mode and tamper disabled, learn-in the keypad by pressing TEST and 1, the keypad will beep and transmit a learn signal. The siren will confirm.
- 4 Press OFF twice on the keypad to exit the program mode.
- 5 Exit learn mode and enable tamper.

Changing the user PIN code

- 1 Put the keypad into program mode by entering the 0000 default code and pressing TEST.
2. Enter 0000 then CLR, enter your new 4 digit PIN code and press PROG, the keypad will beep to confirm.
 - Write your code in the space provided on the inside back cover so you don't forget it.
3. Press OFF twice on the keypad to exit the program mode.
 - If an unauthorised user attempts to guess the code by entering random four digit numbers, the keypad will produce a series of warning beeps. On a fourth wrong attempt, it will lock out for one minute.
 - It is advisable to use the same code if more than one keypad is fitted to prevent confusion.

Using

To arm the alarm:

Enter your PIN code and press Arm.

To disarm:

Enter your PIN code and press Off.

- The Home button is not operational in this system.

Entry and exit delay

The keypad has a 20 second entry and exit delay to allow time for the keypad or entry/exit door to be reached without causing an alarm.

- During the entry delay, any alarm detected will not activate the siren until after the delay period ends.

Warning If the system is armed with the keyfob and disarmed with the keypad, a false alarm could result. This is because the keyfob does not introduce an automatic entry and exit delay.

Tamper

If the keypad is removed from its mounting the tamper switch will sound the alarm.

The keypad will produce a periodic beep if the tamper switch has been activated. The keypad must not be left in this state as the battery will quickly be exhausted.

Adding the help watch

Programming

- 1 With the system in learn mode and tamper disabled, press the help watch button until confirmed (approx 3 seconds).
- 2 Exit learn mode and enable tamper protection using the keyfob.

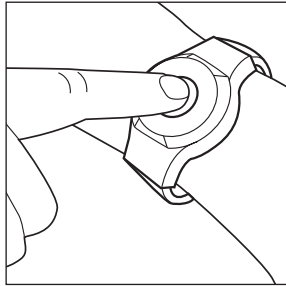

Using

The help watch is worn on the wrist like a watch.

Deliberately pressing the button for 3 seconds will activate the alarm. Pressing the button continuously for 10 seconds will cancel the alarm.

The watch is water resistant and can be worn while in a bath or shower.

Adding the smoke detector

- 1 Follow sections 1, 3 and 4 (Inserting batteries, Location planning and Mounting).
- 2 With the system in learn mode and tamper disabled, press the learn button on the smoke detector until confirmed (approx 3 seconds).
 - The detector will sound an alarm during this time.
- 3 Exit learn mode and enable tamper protection using the keyfob.
 - The smoke detector will indicate a fire by sounding the built-in siren, lighting the LED, and sounding the external siren.
 - The LED flashes briefly every 10 seconds to indicate that it is working, and lights to identify the source of the alarm.
 - The smoke detector will produce a warning beep every 10 seconds if the battery is near exhaustion.
 - The button can be used to test the smoke detector only if depressed for a few seconds. If pressed for more than 10 seconds the siren will be activated too. Test the smoke detectors regularly.

Adding further PIR's and door/window contacts

- 1 Disable tamper and enter learn mode using the keyfob.
- 2 Press the learn button in the device. The siren will confirm.
- 3 Exit learn mode and enable tamper protection using the keyfob.

Using the keypad accessory for learning in detectors

The keypad can be used to learn-in new devices as well as the keyfob.

- 1 Enter the PIN code and press TEST. The keypad Tx LED will flash showing that it is in program mode.
- 2 Disable tamper by pressing TEST and 2, the keypad will beep and the siren will confirm.
- 3 Enter learn mode by pressing TEST and 4, the keypad will beep and the siren will confirm. The system is now in learn mode.
- 4 Learn-in the appropriate device.
- 5 Exit learn mode by pressing TEST and 5, the keypad will beep and the siren will confirm.
- 6 Enable tamper by pressing TEST and 3, the keypad will beep and the siren will confirm.
- 7 Exit programming by pressing OFF twice.

Changing the batteries

Always use alkaline batteries as replacements to ensure long service life. The typical life of the batteries is 2 years.

Siren

The siren will produce a series of pips when armed and disarmed, and an interrupted alarm sound (if activated) if the siren batteries are near exhaustion. Change the batteries as soon as possible. The sound will be reset when the batteries are changed.

- When changing the batteries allow the battery detection feature time to reset by waiting a minute after removing the old batteries before replacing them with new alkaline replacements.
- The difference between a tamper alert and a low battery alert can be determined by arming and disarming the system. If there are 5 pips when the system is armed and disarmed, the batteries are low. If there are 5 pips only when the system is armed, this means the siren tamper has been disturbed.

PIR and door contact

The LED will flash everytime the device is activated indicating a low battery.

- Before changing the battery check that the tamper switch is operating correctly.
- 1 Disable tamper as described below.
 - 2 Remove device from mounting.
 - 3 Change the batteries with alkaline replacements.
 - 4 Screw device back on.
 - 5 Enable tamper protection as described below.

Keyfob

The LED will either be very dim or will not light at all when the battery is low. Change the battery as soon as possible with an alkaline replacement.

Keypad

The Tx will flash repeatedly everytime the device is used indicating a low battery.

- Before changing the battery check that the tamper switch is operating correctly.
- 1 Disable tamper as described below.
 - 2 Remove keypad from mounting.
 - 3 Change the battery with alkaline replacement.
 - 4 Screw keypad back on.
 - 5 Enable tamper protection as described below.

Smoke detector

The LED will flash and the sounder will beep periodically to signal low battery. Change the battery as soon as possible with an alkaline replacement.

Help watch

The help watch has a permanent battery that will last at least ten years and cannot be replaced.

Disable and enable tamper

The keyfob or the keypad accessory can be used to disable and enable the tamper feature to allow batteries to be changed in any device without causing an alarm.

Using the keyfob

- 1 Disable tamper by pressing the Arm and Home buttons simultaneously until the siren confirms (approx 5 seconds). The keyfob LED will also flash.
 - 2 Change the batteries, ensuring you use alkaline ones.
 - 3 Enable tamper by pressing the Arm and Panic buttons simultaneously until the siren confirms (approx 5 seconds).
- If accidentally left in the tamper disable mode, the system will revert to normal after about 1 hour.

Using the keypad

- 1 Enter the PIN code and press TEST. The keypad Tx LED will flash showing that it is in program mode.
- 2 Disable tamper by pressing TEST and 2, the keypad will beep and transmit the signal. The siren will confirm.
- 3 Change the batteries, ensuring you use alkaline ones.
- 4 Enable tamper by pressing TEST and 3.
- 5 Exit programming by pressing OFF twice.

YALE SECURITY PRODUCTS UK LTD

Wood Street, Willenhall,
West Midlands,
England, WV13 1LA

EC Declaration of Conformity

We: Yale Security Products UK Limited
Wood Street
Willenhall
West Midlands
WV13 1LA
UK

declare under our sole responsibility that the following product(s):

Model: HSA3000
HSA3020
HSA3060
HSA3010
HSA3050
HSA3040
HSA3080
HSA3030
HSA3070

is (are) in conformity with the following relevant harmonised standards:

EN 300 220-1
ETS 300 683

following the provisions of Council Directive 1999/5/EC on radio equipment and telecommunications terminal equipment and the mutual recognition of their conformity,

Name: Martin Wakeman Position: Financial Director

Signature:  Date: 26/7/00

On behalf of Yale Security Products UK Limited

Intelligent Security & Fire Ltd

Specifications

All devices

EMC

Tested to EN 300 220-1 and ETS 300 683

Environmental conditions

-10°C to 40°C, relative humidity 70% non-condensing for all units except the external siren. Siren: -20°C to 50°C, relative humidity 95% non-condensing

Radio operational range

30m in a typical domestic installation, range can vary depending on building construction, device positions and RF environment

Housings

ABS/polycarbonate

Siren

Siren output 104dBA sound pressure @ 1m minimum

Radio 433.92MHz AM super heterodyne receiver with jamming detection

Power supply 6V, 4 X D alkaline cells. 2 years typical service life

Passive infra red (PIR) detector

Alarm processing Microprocessor controlled dual edge sequential pulse count with pulse length discrimination

Radio 433.92MHz AM transmitter

Power supply 4.5V, 3 X AA alkaline cells. 2 years typical domestic service life, 1-minute sleep timer

Movement detection range 15m, 110°

Door/window contact

Radio Microprocessor controlled 433.92MHz AM transmitter

Power supply 3V, 2 X AAA alkaline cells. 2 years typical domestic service life

Smoke detector

Radio Microprocessor controlled 433.92MHz AM transmitter

Power supply 9V alkaline PP3. 2 years typical domestic service life

Keyfob

Radio Microprocessor controlled 433.92MHz AM transmitter

Power supply 12V alkaline miniature "lighter" battery. 2 years typical domestic service life

Keypad

Radio Microprocessor controlled 433.92MHz AM transmitter

Power supply 9V alkaline PP3. 2 years typical domestic service life

Help watch

Radio Microprocessor controlled 433.92MHz AM transmitter

Power supply Sealed for life lithium battery, typical domestic service life 10 years

Environmental conditions Water resistant to a depth of 1m



0560



Trouble shooting

Siren

Siren does not respond to keyfob controller

- Keyfob not switched on. Check it is switched on and the LED illuminates brightly when the keyfob buttons are pressed.
- Keyfob buttons are not pressed long enough. Press the buttons deliberately for at least 1 second.
- Keyfob low battery or bad connection. Check battery connections and polarity, if OK replace battery with alkaline equivalent.
- Siren batteries are completely exhausted. Check siren batteries by removing siren cover, if there is no tamper alarm when removed, replace batteries with new alkaline equivalents.
- Keyfob not learnt-in. If siren produces a tamper alarm when the cover is removed, and keyfob is OK, learn-in the keyfob.

Siren produces a 3 second alarm when disarmed

- There has been a previous alarm and there might be an intruder still in the premises.

Siren produces a series of pips when armed or disarmed

- The siren has low batteries. Check that the siren produces a series of pips when arming and disarming, indicating low batteries. Change batteries with new alkaline replacements.
- The siren tamper switch has been disturbed. Check that the siren produces a series of pips only when arming, indicating a tamper fault. Check that the siren cover is firmly secured and the tamper switch plunger is in contact with the wall. If not use suitable packing material to fill gap.

Siren produces an interrupted tone when sounding an alarm

- The siren has low batteries. Change batteries with new alkaline replacements.

PIR

PIR does not respond to movement

- Previous movement has triggered the PIR sleep timer is preventing subsequent movement detection. Arm system and vacate protected room for at least 1.5 minutes before testing.

PIR is slow to respond

- This is normal, the PIR has sophisticated false alarm filtering that will filter out random fluctuations and responds to genuine movement across field of view, it is less sensitive walking directly towards it.

PIR gives false alarms

- Check pets have no access to protected area.
- Check that PIR is not pointed at sources of heat or moving objects, e.g. fluttering curtains.
- Check that PIR is not mounted above convector heaters or pointing directly at windows.

PIR LED flashes when jumper is in normal position

- Batteries are low or the tamper switch is disturbed. Check that the tamper switch spring is making contact with base. If the tamper switch is OK, change batteries with new alkaline replacements.

PIR does not respond to movement when jumper is in test position

- Batteries are completely exhausted. Change batteries with new alkaline replacements, LED will flash for 30 seconds while components initialise.

Door contact

Door contact LED flashes when jumper is in normal position

- Batteries are low or the tamper switch is disturbed. Check that the tamper switch spring is making contact with the mounting surface. If the tamper switch is OK, change batteries with new alkaline replacements.

Door contact does not respond to door opening when jumper is in test position

- Batteries are completely exhausted. Change batteries with new alkaline replacements
- The magnet is too far away from the door contact. Check that the gap between door contact and magnet is not greater than 8mm.

Notes

My PIN code

Intelligent Security & Fire Ltd

®



Key points

Stopping the alarm

- Press Disarm on the keyfob
- Key in your PIN code and press Off on the keypad accessory

If any of the devices beep or flash, they have either

been tampered with

See trouble-shooting, page 18

or require a new battery

See how to change a battery, page 15

Intelligent Security & Fire Ltd



<http://www.yale.co.uk>
E-mail: info@yaleuk.com



Yale Security Products UK Ltd.

Wood Street, Willenhall, West Midlands,
WV13 1LA
Yale is a registered trademark